

This lens with beam splitter for axial illumination is optimized for 16k / 5 $\mu$ m (82 mm) line scan sensors. The lens provides high performance at >72 LP/mm with low color shift and detects the smallest targets to solve the most challenging applications. The V-Mount interface makes it easy to install mounts and to rotate the lens into the highest performance.

## Key features

- High resolution over the entire field
- Low chromatic focal shift
- No rel. illumination loss at the edge
- Axial In-line Illumination

## Applications

- PCB inspection
- Flat Panel inspection
- LCD inspection
- Alignment tasks

## Technical specifications

Type [with beamsplitter]	V70-BS
ID [with beamsplitter]	1099014
Interface	V70-Mount
Focal length [mm]	82
F/# range	F/1.6 ... F/11
Numerical aperture [object   image]	0.21   0.04
Max. sensor size [mm]	82
Max. angle of view [°]	8
Rec. magnification range	-5 (-5.1 ... -4.9)
Rec. working distance range [mm]	34.0 (33.6 ... 34.4)
Max. mechanical focus travel [mm]	24.4
Filter thread [mm]	M62 x 1
Storage temperature [°C]	0 ... +50
Net. weight [g]	1170
Additional info	Max. chief ray angle in object space = 2.9°
f'eff [mm]	82.23
SF [mm]	-18.53
S'F' [mm]	-31.82
HH' [mm]	-17.62
$\beta$ 'P	0.81
SEP [mm]	82.63
S'AP [mm]	-98.67
$\Sigma$ d [mm]	160.13

## MTF charts

Spectrum name	VIS LED					
Wavelengths [nm]	425	475	525	575	625	675
Rel. weights [%]	1.5	13.6	26.5	27.8	24.2	6.4

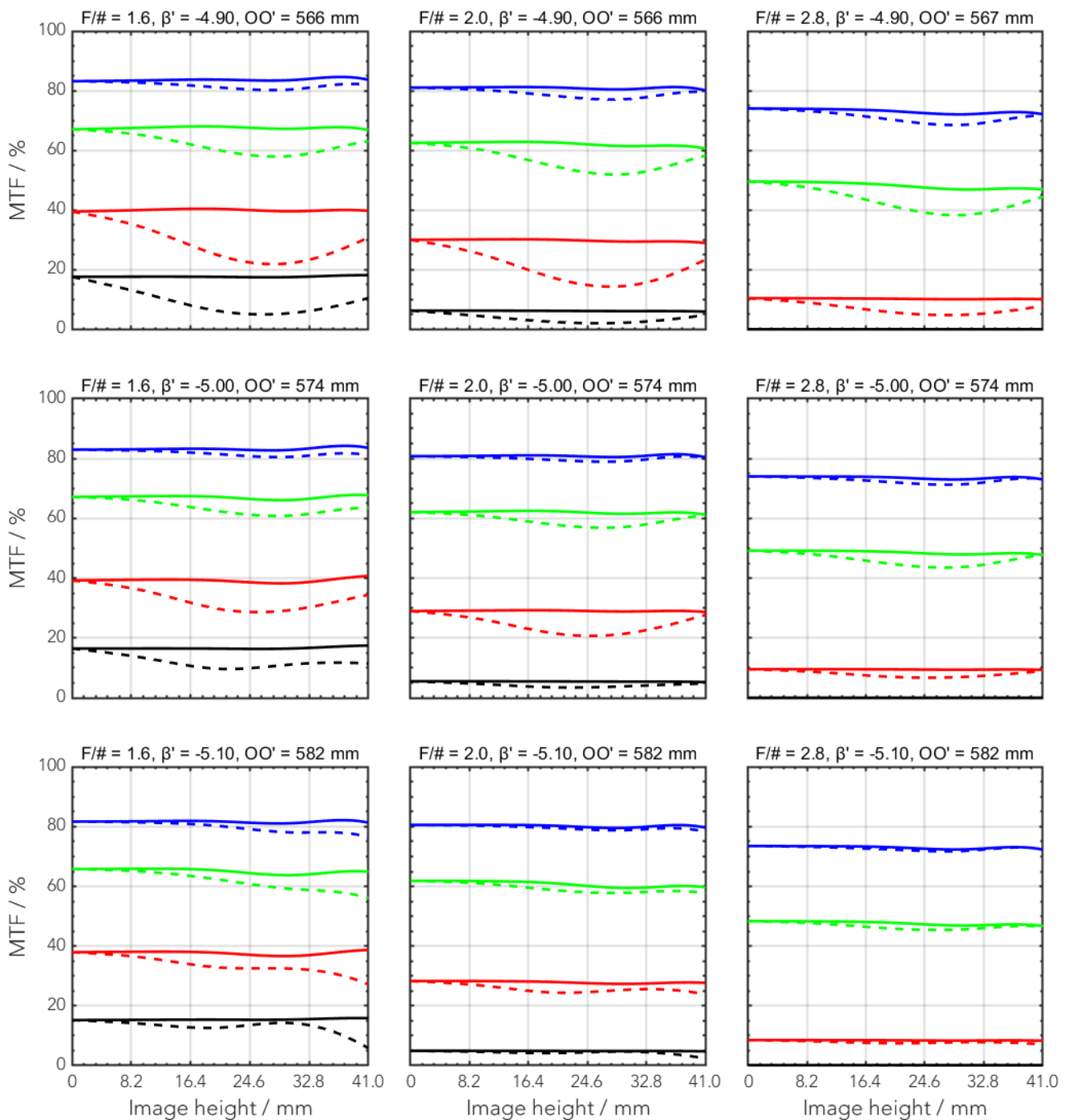

— 18 LP/mm, radial   
 — 36 LP/mm, radial   
 — 72 LP/mm, radial   
 — 108 LP/mm, radial  
- - - 18 LP/mm, tangential   
 - - - 36 LP/mm, tangential   
 - - - 72 LP/mm, tangential   
 - - - 108 LP/mm, tangential

## Rel. illumination vs. image height

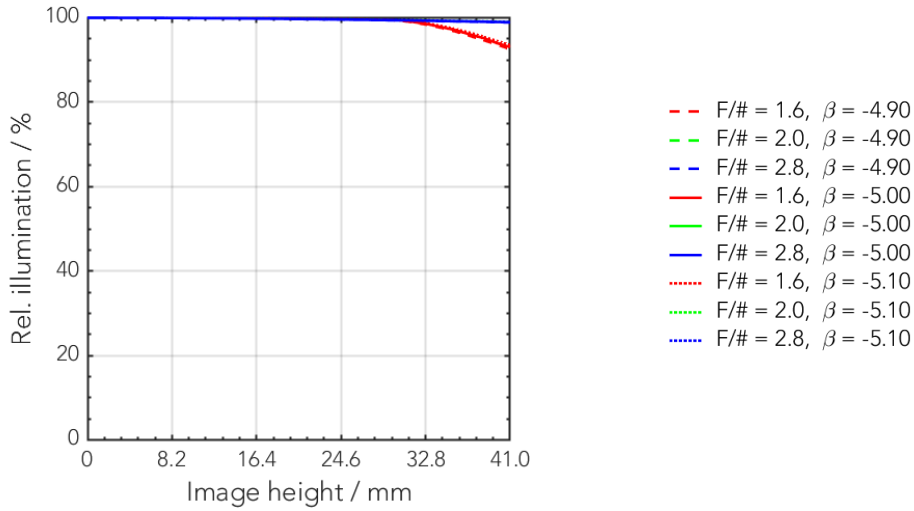

## Distortion vs. image height

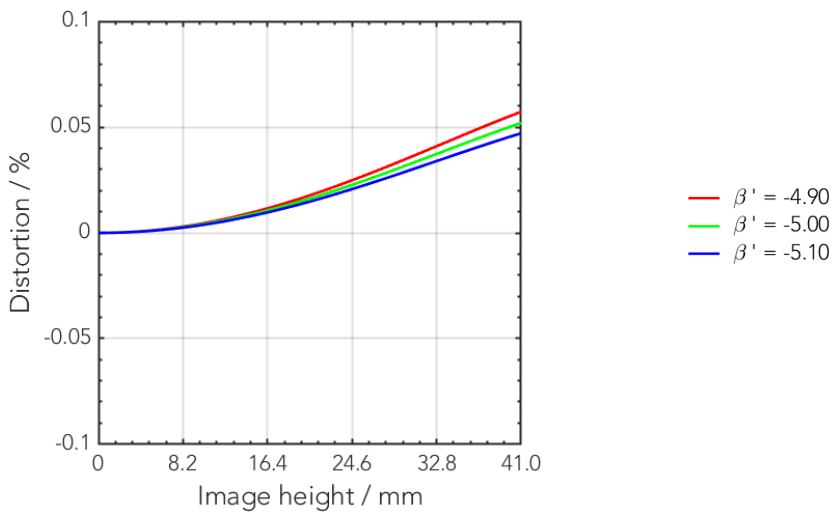

## Transmittance vs. wavelength

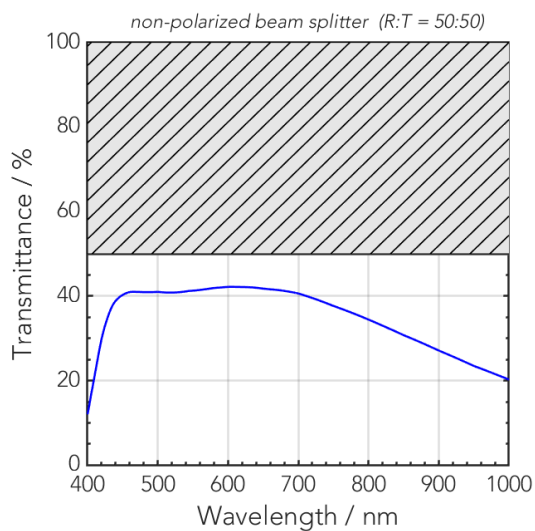

## Technical drawings

\* WD and s'A  
in air at  
beta' -5.00

view without  
transport protection

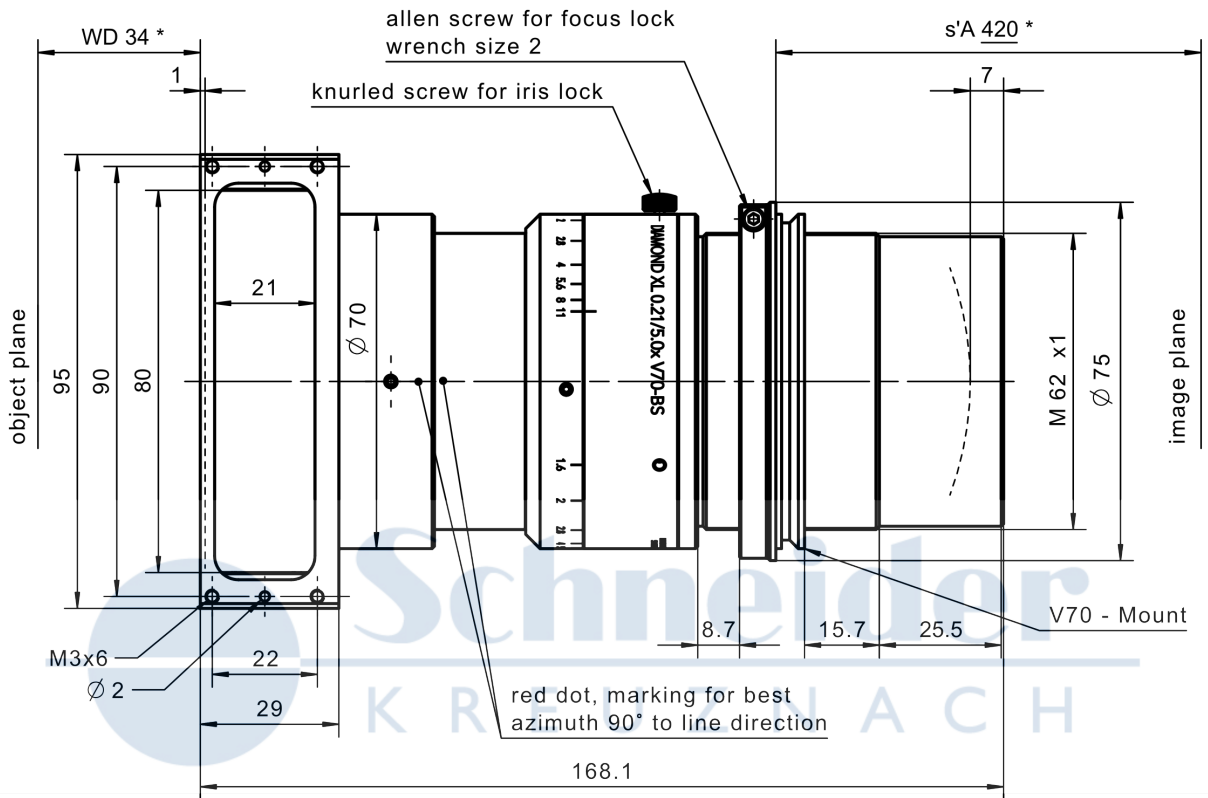

screws for  
beamsplitter  
mount  
wrench size 1.5

transport  
protection

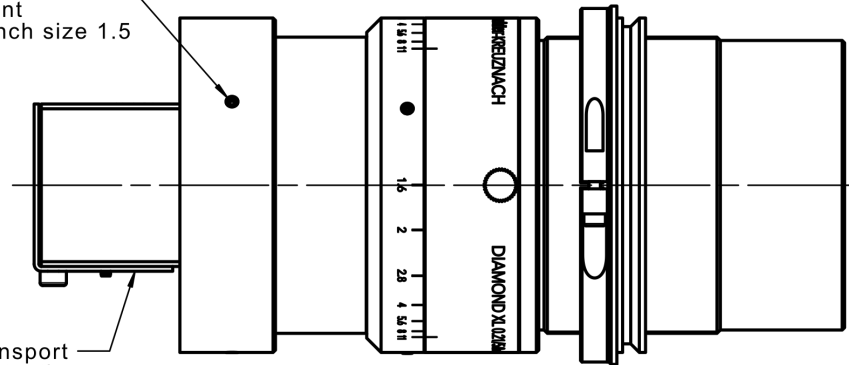

Accessories	Mount	Eff. length	ID
Adapter	V70 / M72 x 0.75	10 mm	1072419
Extension tube	M72 x 0.75 / M72 x 0.75	5 mm	1072420
	M72 x 0.75 / M72 x 0.75	10 mm	1072421
	M72 x 0.75 / M72 x 0.75	25 mm	26406
	M72 x 0.75 / M72 x 0.75	50 mm	1054733

Annotation	
Focal length	Nominal focal length
F/# range	Image space F-number range for infinity focus position
Numerical aperture	Maximum real numerical aperture (depending on recommended magnification range either for infinity or respective fixed magnification)
Max. sensor size	Image circle diameter
Max. angle of view	Angle of view associated with maximum sensor size (depending on recommended magnification range either for infinity or respective fixed magnification)
Rec. magnification range	Magnification range as recommended by Schneider-Kreuznach
Rec. working distance range	Working distance, i.e. distance between object and first mechanical element, associated with recommended magnification range
Max. mechanical focus travel	Maximum possible movement of the lens from infinity position (depending on recommended magnification range either for infinity or respective fixed magnification)
Net weight	weight of unpacked lens without lens cap
$f'_{\text{eff}}$	Effective focal length
SF	Distance between vertex of first lens surface and object space focal point
S'F'	Distance between vertex of last lens surface and image space focal point (back focal distance at infinity)
HH'	Distance between principal planes
$\beta'P$	Pupil magnification (= exit pupil diameter / entrance pupil diameter)
SEP	Distance between vertex of first lens surface and entrance pupil
S'AP	Distance between vertex of last lens surface and exit pupil
$\Sigma d$	Distance between vertices of first and last lens surface
s'A	Flange focal distance (in air) for infinite object distance (depending on recommended magnification range either for infinity or respective fixed magnification)
$\beta'$	Magnification (= image size / object size), negative value because image is inverted
OO'	Distance between object and image

Unless otherwise stated all dimensions in this data sheet are in mm.

## Headquarters Europe

### Jos. Schneider Optische Werke GmbH

Ringstraße 132

55543 Bad Kreuznach

☎ +49 671 601 205

✉ [cs@schneiderkreuznach.com](mailto:cs@schneiderkreuznach.com)

[www.schneiderkreuznach.com](http://www.schneiderkreuznach.com)

## Offices Worldwide

### America

☎ +1 800 645 7239 (East Coast)

☎ +1 800 228 1254 (West Coast)

✉ [info@schneideroptics.com](mailto:info@schneideroptics.com)

### Asia

☎ +86 755 8832 1170

✉ [info@schneider-asiapacific.com](mailto:info@schneider-asiapacific.com)